

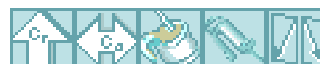

Track rollers LR52

double row, sealed on both sides

The datasheet is only an overview of dimensions and basic load ratings for the selected series. Please ensure that you note all the guidance in these overview pages. Further information is given on many products under the menu item "Description". You can also obtain comprehensive information material via Catalogue selection (<http://www.ina.de/content.ina.de/en/services/mediathek/library/library.jsp>), by e-mail (kataloge@de.ina.com) or telephone +49 (91 32) 82 - 28 97.

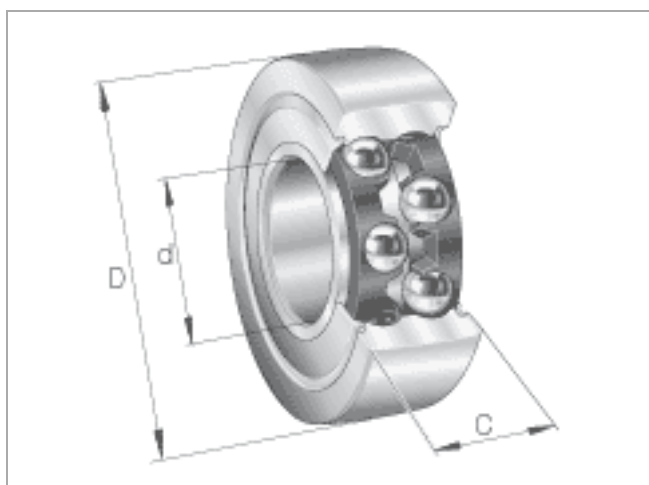

	d mm	D mm	C mm	
LR5200-2RS	10	32	14	
LR5200-2Z	10	32	14	
LR5200-X-2Z	10	32	14	
LR5201-2RS	12	35	15,9	
LR5201-2Z	12	35	15,9	
LR5201-X-2Z	12	35	15,9	
LR5202-2RS	15	40	15,9	
LR5202-2Z	15	40	15,9	
LR5202-X-2Z	15	40	15,9	
LR5203-2RS	17	47	17,5	
LR5203-2Z	17	47	17,5	
LR5203-X-2Z	17	47	17,5	
LR5204-2RS	20	52	20,6	
LR5204-2Z	20	52	20,6	



	d mm	D mm	C mm	
LR5204-X-2Z		20	52	20,6
LR5205-2RS		25	62	20,6
LR5205-2Z		25	62	20,6
LR5205-X-2Z		25	62	20,6
LR5206-2RS		30	72	23,8
LR5206-2Z		30	72	23,8
LR5206-X-2Z		30	72	23,8
LR5207-2RS		35	80	27
LR5207-2Z		35	80	27
LR5207-X-2Z		35	80	27
LR5208-2RS		40	85	30,2
LR5208-2Z		40	85	30,2
LR5208-X-2Z		40	85	30,2
	d mm	D mm	C mm	

Figure 1

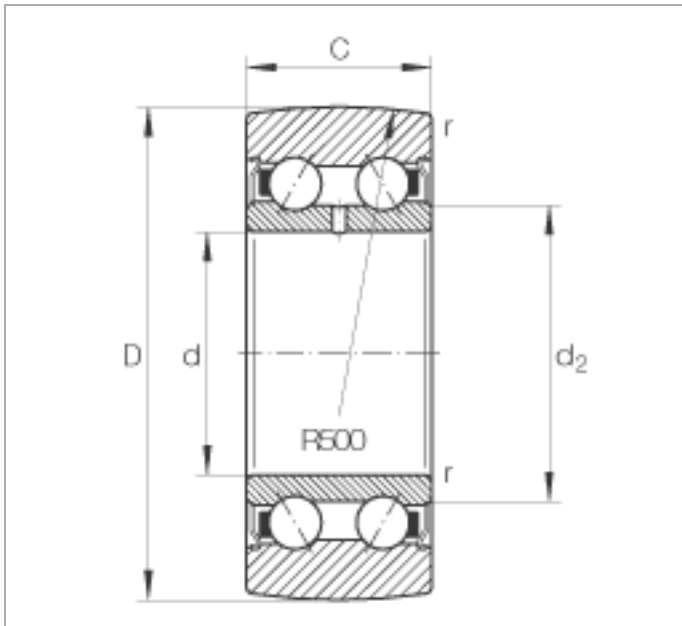

Figure 2

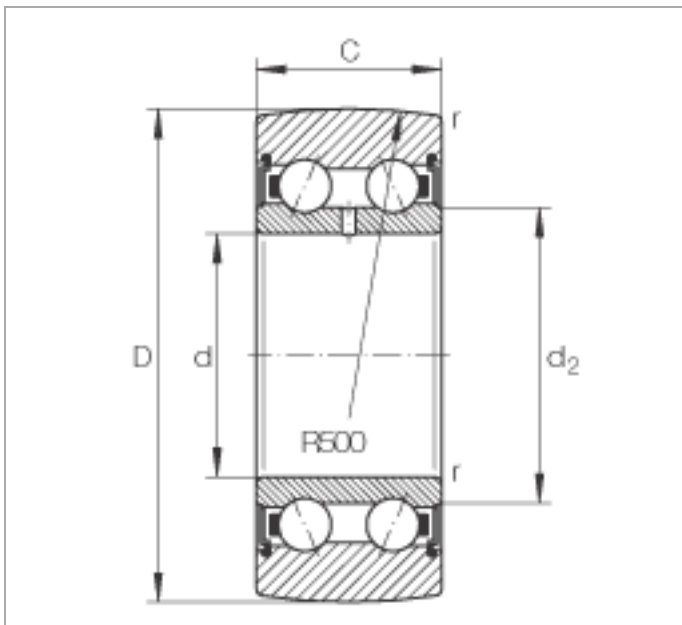
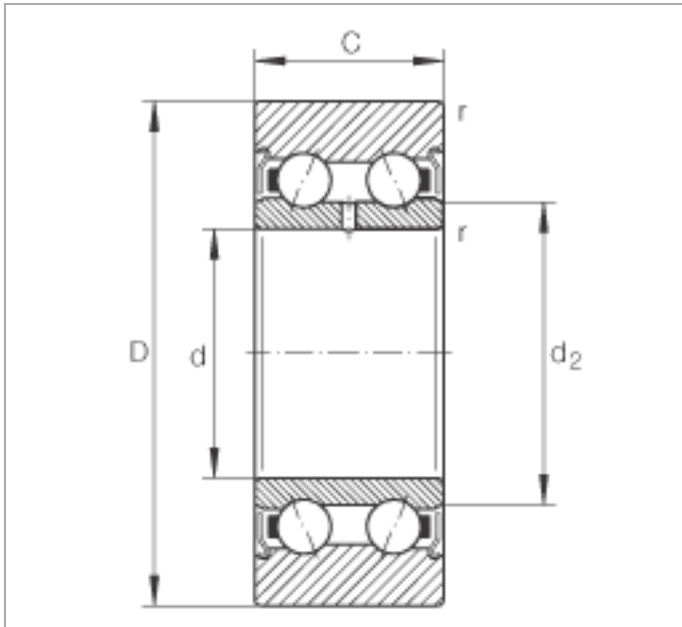

Figure 3



LR5200-2RS

Figure 2

d	10 mm	
D	32 mm	
C	14 mm	
d ₂	15,4 mm	
r _{min}	0,6 mm	
m	0,07 kg	Mass
C _{r w}	6800 N	Effective dynamic load rating as track roller (radial)
C _{0r w}	4100 N	Effective static load rating as track roller (radial)
C _{ur w}	208 N	Fatigue limit load
n _{D G}	8000 1/min	Speed (with continuous operation and grease lubrication)

LR5200-2Z

Figure 1

d	10 mm	
D	32 mm	
C	14 mm	
d ₂	15,4 mm	
r _{min}	0,6 mm	
m	0,07 kg	Mass
C _{r w}	6800 N	Effective dynamic load rating as track roller (radial)
C _{0r w}	4100 N	Effective static load rating as track roller (radial)
C _{ur w}	208 N	Fatigue limit load
n _{D G}	11000 1/min	Speed (with continuous operation and grease lubrication)

LR5200-X-2Z

Figure 3

d	10 mm	
D	32 mm	
C	14 mm	
d ₂	15,4 mm	
r _{min}	0,6 mm	
m	0,07 kg	Mass
C _{r w}	6800 N	Effective dynamic load rating as track roller (radial)
C _{0 r w}	4100 N	Effective static load rating as track roller (radial)
C _{ur w}	208 N	Fatigue limit load
n _{D G}	11000 1/min	Speed (with continuous operation and grease lubrication)
		Track roller with cylindrical outside surface

LR5201-2RS

Figure 2

d	12 mm	
D	35 mm	
C	15,9 mm	
d ₂	17,1 mm	
r _{min}	0,6 mm	
m	0,08 kg	Mass
C _{r w}	8700 N	Effective dynamic load rating as track roller (radial)
C _{0 r w}	5200 N	Effective static load rating as track roller (radial)
C _{ur w}	260 N	Fatigue limit load
n _{D G}	7500 1/min	Speed (with continuous operation and grease lubrication)

LR5201-2Z

Figure 1

d	12 mm	
D	35 mm	
C	15,9 mm	
d ₂	17,1 mm	
r _{min}	0,6 mm	
m	0,08 kg	Mass
C _{r w}	8700 N	Effective dynamic load rating as track roller (radial)
C _{0r w}	5200 N	Effective static load rating as track roller (radial)
C _{ur w}	260 N	Fatigue limit load
n _{D G}	10000 1/min	Speed (with continuous operation and grease lubrication)

LR5201-X-2Z

Figure 3

d	12 mm	
D	35 mm	
C	15,9 mm	
d ₂	17,1 mm	
r _{min}	0,6 mm	
m	0,08 kg	Mass
C _{r w}	8700 N	Effective dynamic load rating as track roller (radial)
C _{0r w}	5200 N	Effective static load rating as track roller (radial)
C _{ur w}	260 N	Fatigue limit load
n _{D G}	10000 1/min	Speed (with continuous operation and grease lubrication)
		Track roller with cylindrical outside surface

LR5202-2RS

Figure 2

d	15 mm	
D	40 mm	
C	15,9 mm	
d ₂	20 mm	
r _{min}	0,6 mm	
m	0,11 kg	Mass
C _{r w}	10000 N	Effective dynamic load rating as track roller (radial)
C _{0r w}	6300 N	Effective static load rating as track roller (radial)
C _{ur w}	320 N	Fatigue limit load
n _{D G}	7000 1/min	Speed (with continuous operation and grease lubrication)

LR5202-2Z

Figure 1

d	15 mm	
D	40 mm	
C	15,9 mm	
d ₂	20 mm	
r _{min}	0,6 mm	
m	0,11 kg	Mass
C _{r w}	10000 N	Effective dynamic load rating as track roller (radial)
C _{0r w}	6300 N	Effective static load rating as track roller (radial)
C _{ur w}	320 N	Fatigue limit load
n _{D G}	10000 1/min	Speed (with continuous operation and grease lubrication)

LR5202-X-2Z

Figure 3

d	15 mm	
D	40 mm	
C	15,9 mm	
d ₂	20 mm	
r _{min}	0,6 mm	
m	0,11 kg	Mass
C _{r w}	10000 N	Effective dynamic load rating as track roller (radial)
C _{0 r w}	6300 N	Effective static load rating as track roller (radial)
C _{ur w}	320 N	Fatigue limit load
n _{D G}	10000 1/min	Speed (with continuous operation and grease lubrication)
		Track roller with cylindrical outside surface

LR5203-2RS

Figure 2

d	17 mm	
D	47 mm	
C	17,5 mm	
d ₂	22,5 mm	
r _{min}	0,6 mm	
m	0,17 kg	Mass
C _{r w}	12800 N	Effective dynamic load rating as track roller (radial)
C _{0 r w}	8400 N	Effective static load rating as track roller (radial)
C _{ur w}	420 N	Fatigue limit load
n _{D G}	5500 1/min	Speed (with continuous operation and grease lubrication)

LR5203-2Z

Figure 1

d	17 mm	
D	47 mm	
C	17,5 mm	
d ₂	22,5 mm	
r _{min}	0,6 mm	
m	0,17 kg	Mass
C _{r w}	12800 N	Effective dynamic load rating as track roller (radial)
C _{0r w}	8400 N	Effective static load rating as track roller (radial)
C _{ur w}	420 N	Fatigue limit load
n _{D G}	7500 1/min	Speed (with continuous operation and grease lubrication)

LR5203-X-2Z

Figure 3

d	17 mm	
D	47 mm	
C	17,5 mm	
d ₂	22,5 mm	
r _{min}	0,6 mm	
m	0,17 kg	Mass
C _{r w}	12800 N	Effective dynamic load rating as track roller (radial)
C _{0r w}	8400 N	Effective static load rating as track roller (radial)
C _{ur w}	420 N	Fatigue limit load
n _{D G}	7500 1/min	Speed (with continuous operation and grease lubrication)
		Track roller with cylindrical outside surface

LR5204-2RS

Figure 2

d	20 mm	
D	52 mm	
C	20,6 mm	
d ₂	26,5 mm	
r _{min}	1 mm	
m	0,23 kg	Mass
C _{r w}	16100 N	Effective dynamic load rating as track roller (radial)
C _{0r w}	10700 N	Effective static load rating as track roller (radial)
C _{ur w}	550 N	Fatigue limit load
n _{D G}	5000 1/min	Speed (with continuous operation and grease lubrication)

LR5204-2Z

Figure 1

d	20 mm	
D	52 mm	
C	20,6 mm	
d ₂	26,5 mm	
r _{min}	1 mm	
m	0,23 kg	Mass
C _{r w}	16100 N	Effective dynamic load rating as track roller (radial)
C _{0r w}	10700 N	Effective static load rating as track roller (radial)
C _{ur w}	550 N	Fatigue limit load
n _{D G}	7000 1/min	Speed (with continuous operation and grease lubrication)

LR5204-X-2Z

Figure 3

d	20 mm	
D	52 mm	
C	20,6 mm	
d ₂	26,5 mm	
r _{min}	1 mm	
m	0,23 kg	Mass
C _{r w}	16100 N	Effective dynamic load rating as track roller (radial)
C _{0 r w}	10700 N	Effective static load rating as track roller (radial)
C _{ur w}	550 N	Fatigue limit load
n _{D G}	7000 1/min	Speed (with continuous operation and grease lubrication)
Track roller with cylindrical outside surface		

LR5205-2RS

Figure 2

d	25 mm	
D	62 mm	
C	20,6 mm	
d ₂	30,3 mm	
r _{min}	1 mm	
m	0,34 kg	Mass
C _{r w}	18800 N	Effective dynamic load rating as track roller (radial)
C _{0 r w}	13200 N	Effective static load rating as track roller (radial)
C _{ur w}	670 N	Fatigue limit load
n _{D G}	4500 1/min	Speed (with continuous operation and grease lubrication)

LR5205-2Z

Figure 1

d	25 mm	
D	62 mm	
C	20,6 mm	
d ₂	30,3 mm	
r _{min}	1 mm	
m	0,34 kg	Mass
C _{r w}	18800 N	Effective dynamic load rating as track roller (radial)
C _{0r w}	13200 N	Effective static load rating as track roller (radial)
C _{ur w}	670 N	Fatigue limit load
n _{D G}	6500 1/min	Speed (with continuous operation and grease lubrication)

LR5205-X-2Z

Figure 3

d	25 mm	
D	62 mm	
C	20,6 mm	
d ₂	30,3 mm	
r _{min}	1 mm	
m	0,34 kg	Mass
C _{r w}	18800 N	Effective dynamic load rating as track roller (radial)
C _{0r w}	13200 N	Effective static load rating as track roller (radial)
C _{ur w}	670 N	Fatigue limit load
n _{D G}	6500 1/min	Speed (with continuous operation and grease lubrication)
		Track roller with cylindrical outside surface

LR5206-2RS

Figure 2

d	30 mm	
D	72 mm	
C	23,8 mm	
d ₂	37,4 mm	
r _{min}	1 mm	
m	0,51 kg	Mass
C _{r w}	25000 N	Effective dynamic load rating as track roller (radial)
C _{0r w}	18000 N	Effective static load rating as track roller (radial)
C _{ur w}	930 N	Fatigue limit load
n _{D G}	3500 1/min	Speed (with continuous operation and grease lubrication)

LR5206-2Z

Figure 1

d	30 mm	
D	72 mm	
C	23,8 mm	
d ₂	37,4 mm	
r _{min}	1 mm	
m	0,51 kg	Mass
C _{r w}	25000 N	Effective dynamic load rating as track roller (radial)
C _{0r w}	18000 N	Effective static load rating as track roller (radial)
C _{ur w}	930 N	Fatigue limit load
n _{D G}	5000 1/min	Speed (with continuous operation and grease lubrication)

LR5206-X-2Z

Figure 3

d	30 mm	
D	72 mm	
C	23,8 mm	
d ₂	37,4 mm	
r _{min}	1 mm	
m	0,51 kg	Mass
C _{r w}	25000 N	Effective dynamic load rating as track roller (radial)
C _{0 r w}	18000 N	Effective static load rating as track roller (radial)
C _{ur w}	930 N	Fatigue limit load
n _{D G}	5000 1/min	Speed (with continuous operation and grease lubrication)
Track roller with cylindrical outside surface		

LR5207-2RS

Figure 2

d	35 mm	
D	80 mm	
C	27 mm	
d ₂	42,4 mm	
r _{min}	1,1 mm	
m	0,66 kg	Mass
C _{r w}	31000 N	Effective dynamic load rating as track roller (radial)
C _{0 r w}	22800 N	Effective static load rating as track roller (radial)
C _{ur w}	1200 N	Fatigue limit load
n _{D G}	2800 1/min	Speed (with continuous operation and grease lubrication)

LR5207-2Z

Figure 1

d	35 mm	
D	80 mm	
C	27 mm	
d ₂	42,4 mm	
r _{min}	1,1 mm	
m	0,66 kg	Mass
C _{r w}	31000 N	Effective dynamic load rating as track roller (radial)
C _{0r w}	22800 N	Effective static load rating as track roller (radial)
C _{ur w}	1200 N	Fatigue limit load
n _{D G}	3900 1/min	Speed (with continuous operation and grease lubrication)

LR5207-X-2Z

Figure 3

d	35 mm	
D	80 mm	
C	27 mm	
d ₂	42,4 mm	
r _{min}	1,1 mm	
m	0,66 kg	Mass
C _{r w}	31000 N	Effective dynamic load rating as track roller (radial)
C _{0r w}	22800 N	Effective static load rating as track roller (radial)
C _{ur w}	1200 N	Fatigue limit load
n _{D G}	3900 1/min	Speed (with continuous operation and grease lubrication)
		Track roller with cylindrical outside surface

LR5208-2RS

Figure 2

d	40 mm	
D	85 mm	
C	30,2 mm	
d ₂	48,4 mm	
r _{min}	1,1 mm	
m	0,75 kg	Mass
C _{r w}	35000 N	Effective dynamic load rating as track roller (radial)
C _{0 r w}	26000 N	Effective static load rating as track roller (radial)
F _{r per}	21100 N	Permissible dynamic radial load
C _{ur w}	1360 N	Fatigue limit load
n _{D G}	2500 1/min	Speed (with continuous operation and grease lubrication)

LR5208-2Z

Figure 1

d	40 mm	
D	85 mm	
C	30,2 mm	
d ₂	48,4 mm	
r _{min}	1,1 mm	
m	0,75 kg	Mass
C _{r w}	35000 N	Effective dynamic load rating as track roller (radial)
C _{0 r w}	26000 N	Effective static load rating as track roller (radial)
F _{r per}	21100 N	Permissible dynamic radial load
C _{ur w}	1360 N	Fatigue limit load
n _{D G}	3500 1/min	Speed (with continuous operation and grease lubrication)

LR5208-X-2Z

Figure 3

d	40 mm	
D	85 mm	
C	30,2 mm	
d ₂	48,4 mm	
r _{min}	1,1 mm	
m	0,75 kg	Mass
C _{r w}	35000 N	Effective dynamic load rating as track roller (radial)
C _{0 r w}	26000 N	Effective static load rating as track roller (radial)
F _{r per}	21100 N	Permissible dynamic radial load
C _{ur w}	1360 N	Fatigue limit load
n _{D G}	3500 1/min	Speed (with continuous operation and grease lubrication)
		Track roller with cylindrical outside surface